



WELCOME TO AJA INTERNATIONAL, INC!

WWW.AJAINT.COM

AJA INTERNATIONAL, INC.

AJA International, Inc. (est. 1989) began as a supplier of innovative thin film, vacuum and microwave products. In 1991 the company introduced the first commercial, con-focal, sputter tool with a rotating substrate and magnetron heads which could be tilted without breaking vacuum. This innovation yielded extremely uniform depositions of single layers, multi-layers and alloys and has become the benchmark by which other R&D sputtering systems are measured - the ATC Series Sputtering System.



AJA International, Inc. has continued to develop many highly successful physical vapor deposition (PVD) tools including the compact ATC ORION Series Sputtering Systems, ATC-E and ATC ORION-E Evaporation Systems, the Stiletto Series HV sputter sources, SHQ Series substrate holders with heating, RF biasing, LN2 cooling, indexing, rotation and planetary motion, PHASE II Labview based, "plug and play" computer control systems, the STXL Series of large circular & rectangular magnetrons with modular magnet arrays, the Nautilus Series rotating "modular" magnetrons, automated combinatorial deposition systems, various ATC-B batch coating systems, a UHV downstream microwave oxygen plasma source, & a patented conical target magnetron which is ideal for three dimensional coatings & OLED applications.

AJA International, Inc. continues to discover innovative design solutions which are often copied but never equaled as the company truly remains THE CUTTING EDGE IN THIN FILM TECHNOLOGY.

HOT NEWS AT AJA INTERNATIONAL, INC.



ATC ORION SERIES SPUTTERING SYSTEMS *Compact, Powerful UHV Tool for PVD*

AJA International, Inc. introduces the highly versatile, compact, ATC ORION Series Sputtering System which inherits many design features from the popular, highly evolved ATC Series Sputtering tools and offer some unique features designed to optimize deposition uniformity. 3, 4 and 5 gun versions have been delivered with load-locks, high temperature substrate heaters and computer control. Economical HV versions are also available.



HYBRID SYSTEMS *UHV Sputtering & Evaporation*

AJA International Inc. has delivered numerous multi-chamber "HYBRID" physical vapor deposition (PVD) systems. This dual chamber UHV system contains (4) A320-XP 2" sputter sources with in-situ tilt in the sputter chamber and (2) K cells plus (1) 4 pocket e-gun in the evaporation chamber. Each chamber is fitted with an 850° C rotating substrate heater. A single load-lock introduces the substrate and magnetic arms transfer it between chambers.

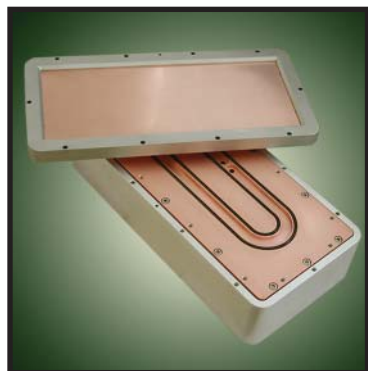

STXL SERIES *Large Magnetron Sputtering Sources*

AJA International, Inc. introduces the STXL Series of large magnetron sputter sources with a versatile modular magnet system. Circular target models range from 6" - 12" diameter. Rectangular versions in 3", 4" or 6" widths are offered up to 40" long. Both internal mount (via flex hose or solid tube) and external flange mount designs are available. High strength rare earth magnets are located outside the cooling water and are easily accessed for magnet modification. Sources can accommodate target materials bonded to a backing plate or one piece targets. Backing plates are directly water cooled for maximum cooling efficiency. 7/16 DIN coaxial cable powered DC sources and RF versions with close coupled matchboxes are offered for high power.

PRODUCT OVERVIEW

SPUTTER SOURCES / SPUTTERING SYSTEMS / PVD EQUIPMENT:

AJA manufactures ATC and ATC ORION magnetron sputtering systems; PVDX e-beam / thermal / sputter multi-technique deposition systems; A300-XP, A3CV, Stiletto and Nautilus magnetron sputter sources; peripheral equipment for substrate heating, cooling, RF biasing and motion. Sputtering systems are configured primarily for R&D and pilot production with either UHV or HV construction. AJA International, Inc. also manufactures a wide range of magnetron sputter sources for R&D and production applications ranging in target size from 1" to 40" and up to 12" ID cylindrical. Nautilus Series rotating magnetron sputtering sources are designed for production coating tools. AJA also offers sputter targets, PVD materials, and RF / DC power supplies and switchboxes for sputter deposition.

MICROWAVE:

AJA International, Inc. is the exclusive US distributor for Sairem microwave generators, power supplies, tuners, circulators, dummy loads, waveguide components, power splitters and microwave detectors. With extensive experience, the AJA / Sairem combination will find a cost effective solution to your microwave application requirement.

COMPANY PHILOSOPHY AND RESPONSIBILITY

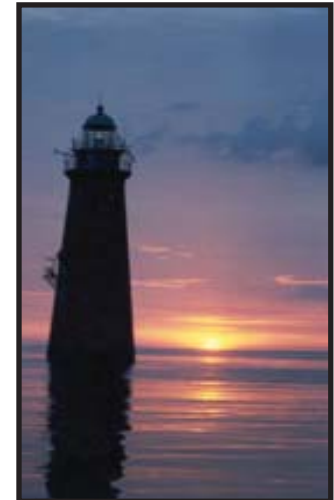

Company Headquarters, North Scituate, MA, USA
Located one mile from the Atlantic Coast

It has always been the primary philosophy of AJA to expand conservatively, manufacturing and representing products of exceptional value, while relying on customer satisfaction and technical excellence as our primary promotional vehicles. The company chooses its projects carefully in order to maintain its reputation and financial stability.

Our first responsibility will always be to our customers, since without our customers we are nothing. The interaction between AJA personnel and their customers must be a positive, professional and efficient experience. Anyone calling AJA International, Inc. will always speak to a person and will never be routed through the impersonal frustration of an automated answering system. At AJA, we consider your time as valuable as our own.

To all of our customers, thank you for your continued support.

A handwritten signature in black ink, appearing to read 'William Hale'.

William Hale
President

www.ajaint.com

 **AJA INTERNATIONAL, INC.**

topgun@ajaint.com

809 COUNTRY WAY * NORTH SCITUATE, MA 02066 * USA * T: 781-545-7365 * F: 781-545-4105



SPUTTERING SOURCES

WWW.AJAINT.COM/SOURCES.HTM

AJA INTERNATIONAL, INC.

STILETTO SERIES: HV R&D Sputtering Sources



A300 SERIES: UHV R&D Sputtering Sources



PRODUCTION SPUTTERING SOURCES: Several Models



SPECIALTY SPUTTERING SOURCES: Several Models



www.ajaint.com



AJA INTERNATIONAL, INC.

topgun@ajaint.com

809 COUNTRY WAY * NORTH SCITUATE, MA 02066 * USA * T: 781-545-7365 * F: 781-545-4105



SPUTTERING SYSTEMS

WWW.AJAINT.COM\SYSTEMS.HTM

AJA INTERNATIONAL, INC.

ATC ORION SPUTTERING SYSTEMS: Compact Series



- Range: \$50,000 - \$300,000
- Available with Load Lock or N2 Glove Box
- 10" - 14" Chamber Diameter
- Cluster Flange Options
- Compact, economical design
- HV & UHV Versions
- Configured for your application

ATC SPUTTERING SYSTEMS: Flagship Series



- Range: \$100,000 - \$650,000+
- 13" - 34" Chamber Diameter
- HV & UHV Versions Available
- Load Lock Chamber & Cassette Options
- In-Situ Tilt Magnetrons
- Integrated Hoist or Hinged Chamber Lid
- Configured for your application

ATC-B SPUTTERING SYSTEMS: Batch Coating Series



- Range: \$70,000 - \$650,000+
- Cylindrical and In-line chamber configurations
- Special magnetron sources for extended operations
- Custom substrate holders and fixturing
- DC, Pulsed DC and RF
- HV & UHV Versions
- Customized for your application

www.ajaint.com



AJA INTERNATIONAL, INC.

topgun@ajaint.com

809 COUNTRY WAY * NORTH SCITUATE, MA 02066 * USA * T: 781-545-7365 * F: 781-545-4105



ATC SERIES SPUTTERING SYSTEMS

AJA INTERNATIONAL, INC.

GENERAL INFORMATION

The AJA International, Inc. ATC Series Thin Film Deposition Systems are versatile coating tools that can be built in a wide variety of configurations to satisfy almost any requirement. These systems are built around AJA's unique A300-XP (UHV) or Stiletto Series (HV) magnetron sputtering sources which feature in-situ source head tilting allowing precise and repeatable con-focal, direct, and off-axis deposition. Larger systems are fitted with a heavy duty hydraulic hoist to lift the chamber top for system access - the chamber top swings to either side at the top of the hoist's stroke. Medium and small ATC systems feature a hinged top with gas shock assist mechanism for easy chamber access.

Substrate holders from 1" to 10" diameter are available with heating to 1000° C and/or substrate cooling from ambient to LN2 temperatures. AJA magnetron sputter sources from 1" diameter to 12" diameter plus rectangular and triangular versions can be incorporated.

These multi-technique deposition systems can also be fitted with electron beam evaporation, thermal evaporation, Knudsen cells, PLD, ion sources for IBAD, facing target sputtering sources (FTS), contact masking systems, glove boxes, auto-loading cassette systems, RHEED, Auger analysis, and RGA's.

TYPICAL SYSTEM CONFIGURATIONS

- ATC 1300 (13" diameter)*
- ATC 1500 (15" diameter)*
- ATC 1800 (18" diameter)*
- ATC 2000 (20" diameter)*
- ATC 2200 (22" diameter)*
- ATC 2400 (24" diameter)*
- ATC 2800 (28" diameter)*

* The maximum number of sputter sources will depend on the substrate size, configuration and magnetron sputter source size. For example, the ATC 1800 can be fitted with (5) 2" magnetrons with in-situ tilt. AJA offers 1", 1.5", 2", 3", 4" diameter, rectangular and triangular sources on the ATC Series. Consult factory for optimum configuration.



ATC 2000 with (6) A320-XP 2" UHV sputter sources with in-situ tilt, 1200 l/s turbopump, 850°C rotating substrate heater with RF bias, computer control and (6) substrate cassette elevator in the load-lock for 4" substrates.



ATC 2200 IBAD with (3) A340-XP 4" UHV sputter sources with in-situ tilt, a COPRA ICP plasma/ion source for ion beam assisted deposition below 5×10^{-4} Torr, 1200 l/s turbopump, 800°C rotating substrate heater with RF bias, computer control and a load-lock for 6" diameter substrates.

TYPICAL SYSTEM CONFIGURATIONS



ATC 1300 with (3) ST20 2" HV sputter sources with manual tilt, 210 l/s turbopump, 850° C rotating substrate heater with RF bias and a TSVC touch screen valve controller for automated shutter sequencing.



Dual UHV ATC 1500's (Sputter & Mini MBE) with (4) A320-XP 4" UHV sputter sources with in-situ tilt, (4) Knudsen cells, RHEED, 1200 l/s turbopumps, 850° C rotating substrate heaters with RF bias, computer control, load-lock for 3" diameter substrates and chamber to chamber transfer system.

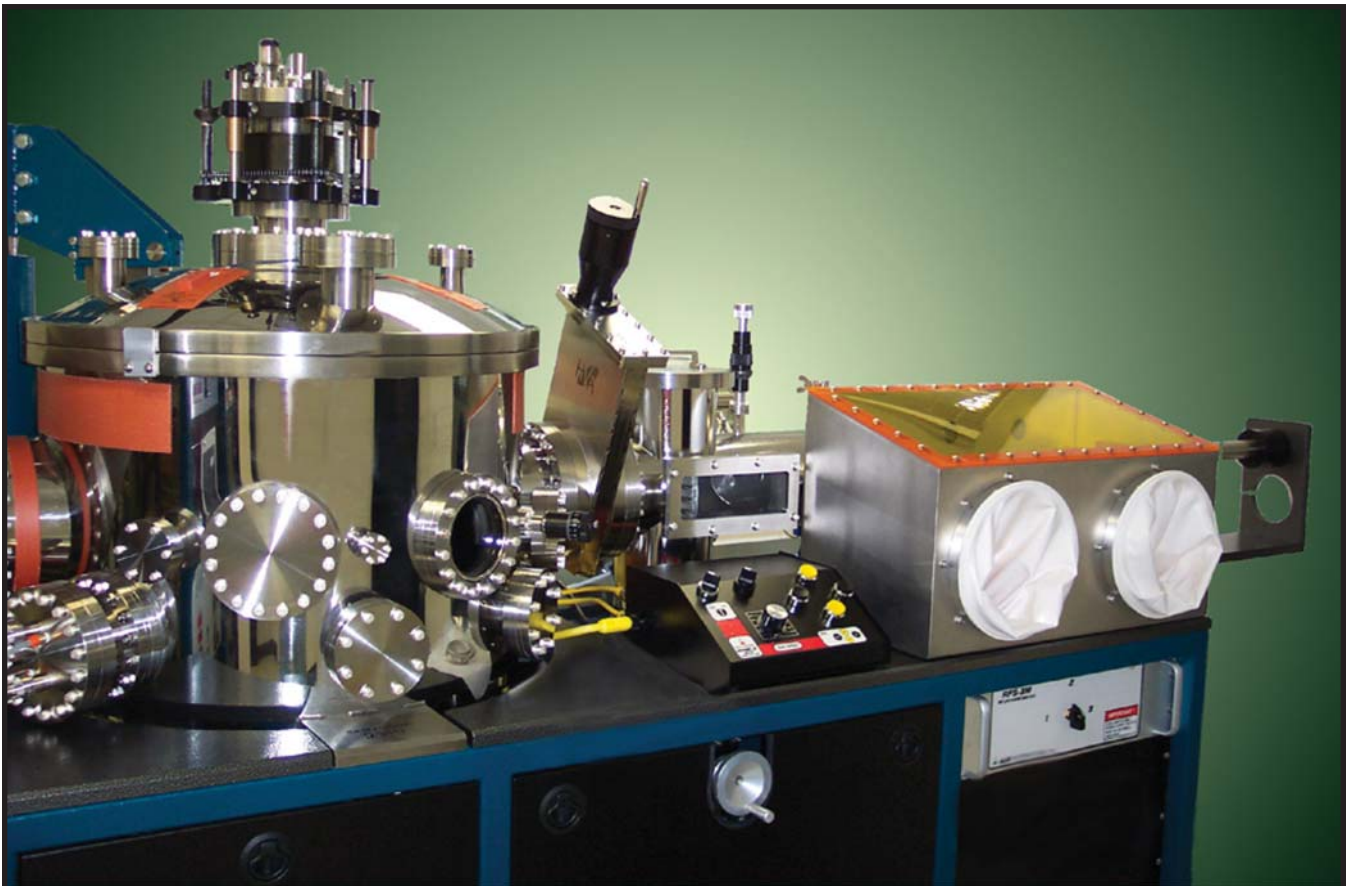

ATC 2400 with (6) A320-XP 2" UHV sputter sources with in-situ tilt, (1) A3CV-HP 3.5" UHV sputter source for high pressure depositions, 1200 l/s turbopump, 600° C rotating substrate heater with RF bias, (6) position cassette load-lock with contact mask exchange, N₂ glovebox for controlled environment substrate loading, and quartz lamp bakeout capability.

TYPICAL RATE / UNIFORMITY DATA

The ATC Series Thin Film Deposition Systems feature dished top and bottom flanges with individual ports to accommodate deposition sources and substrate holders. Systems can be configured for con-focal, direct, and off-axis deposition. Con-focal deposition with in-situ tilt compatible sputter sources (AJA pioneered and developed this deposition concept in 1991) can deliver uniformity of better than +/- 2% on substrates twice the diameter of the targets. Often +/- 1% or better is achievable. A typical deposition profile with SiO₂ on a 6" diameter Si wafer is shown below. Sputter deposition rate is a function of sputter yield of the material, maximum allowable power density into the target (depends on heat transfer capability of target material), and type of power used (eg. RF, DC, pulsed DC).

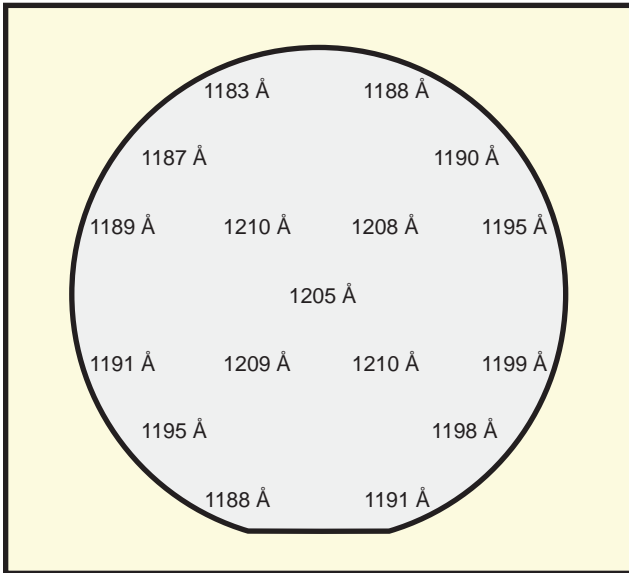

Maximum deposition rates are achieved with materials such as Au - high sputter yield, excellent heat transfer properties and it can be sputtered with DC (most efficient). Slow deposition rates can be expected with materials such as Al₂O₃ - very low sputter yield, poor heat transfer properties and, being non-conductive, it must be sputtered with RF (1/2 the efficiency of DC). Typical rates are 0 - 18 A/sec with Au, 0 - 9 A/sec with Cu and 0 - 0.16 A/sec with Al₂O₃. Off-axis deposition rates are typically 1-5 times lower than con-focal deposition rates depending on substrate size and system configuration.

Direct deposition at short working distances can achieve much higher rates such as 300 Å/sec for Au. The ultimate configuration will depend on the application, but, if extremely high deposition rates are not required, con-focal geometry offers optimum results with the best uniformity, the ability to co-deposit alloy films and the ability to grow better ultra-thin film multilayers since the substrate is always "in the plasma".

ABOVE LEFT: Deposition uniformity with A330-XP (5) Source Cluster Flange featuring in-situ tilt focused on rotating, 6.0" diameter, Si Wafer. SiO₂ deposition shows +/- 1.17% uniformity.

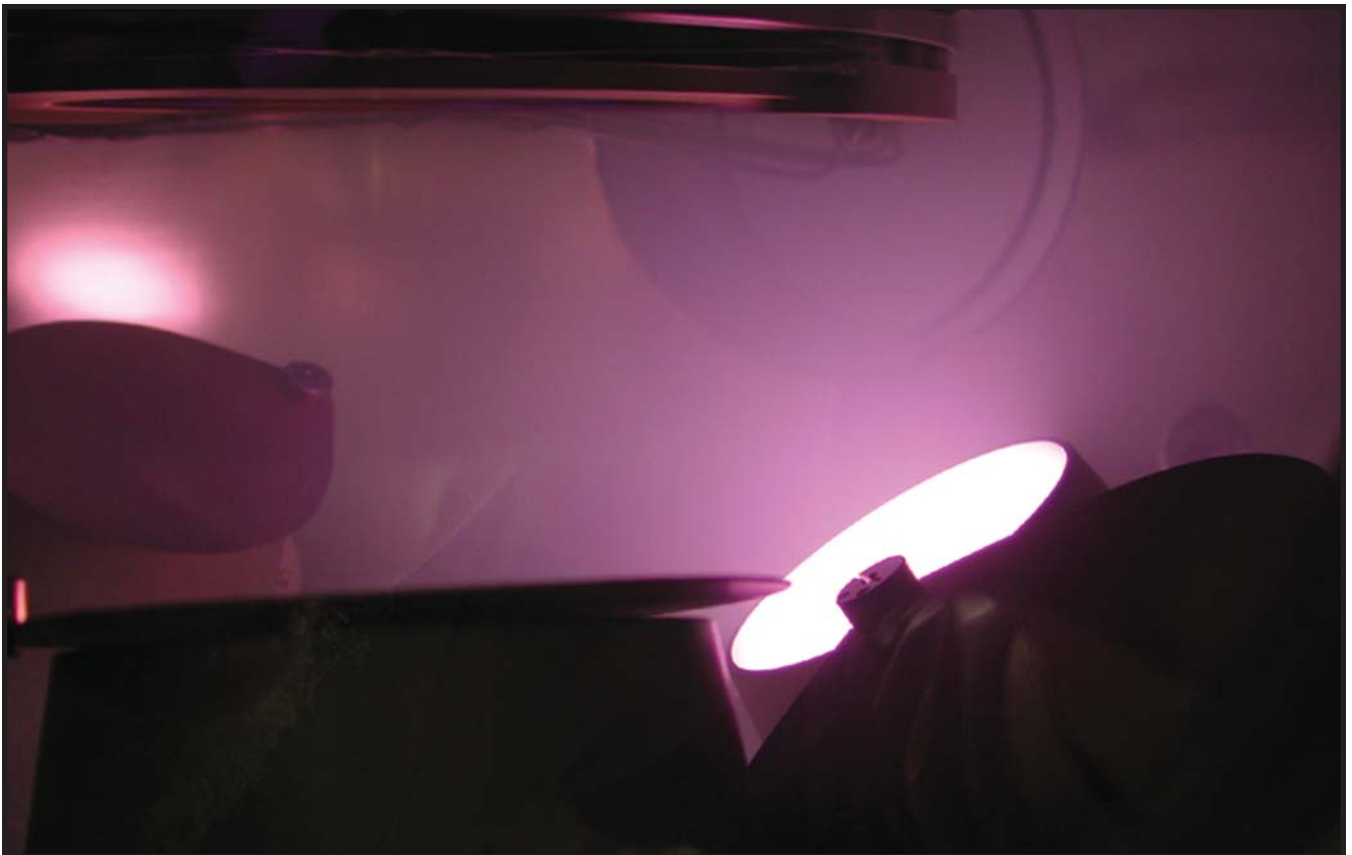

SPUTTER SOURCES

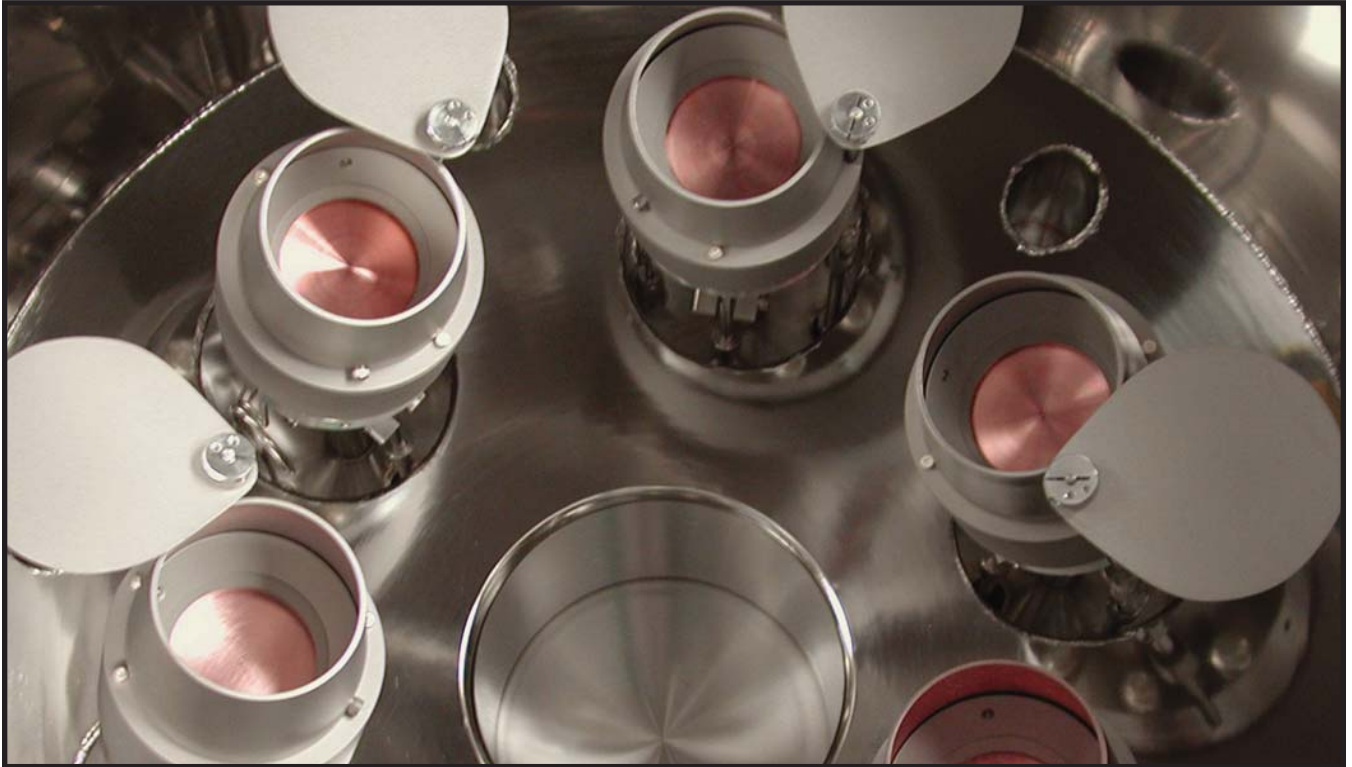

AJA's exclusive Stiletto (HV) and A300 (UHV) Series Magnetron Sputtering Sources are designed for maximum application flexibility. These unique sources feature a modular magnet array which can be configured by the customer to operate in the balanced, unbalanced (Type II) and magnetic material modes. Gas injection chimneys and shutter systems are incorporated to facilitate in-situ tilting and prevent cross-contamination and target poisoning. 3" and 4" sources can be operated at pressures below 4×10^{-4} Torr in combination with an ion source to perform IBAD at half the price and complexity of a dual ion beam system.

UNIQUE MODULAR MAGNET ARRAY / IN-SITU TILT

The A300XP series and Stiletto series feature a unique "modular magnet array" which is completely isolated from the cooling water to eliminate magnet deterioration and subsequent degradation of source performance. This design permits access to the internal magnet arrangement thus allowing the same source to be:

- Configured for uniform or intentionally non-uniform depositions
- Operated as a balanced magnetron
- Configured for maximum target utilization
- Configured for high or low electron energies as they arrive at the substrate surface
- Operated with magnetic material targets and facilitating easy magnet target removal and replacement
- Operated in a variety of unbalanced magnetron configurations
- Configured for high or low rate sputtering

For angled sputtering configurations with rotating substrates, AJA International Inc. sputtering sources can be fitted with the "in-situ tilt" option. This option, shown at the right, allows the source angle to be precisely adjusted from outside the vacuum chamber. Fine tuning the incident angle is critical to achieving good deposition uniformity when working distances, operating pressures and materials are changed. When fixed angle arrangements limit and often compromise the capabilities of a system, "in-situ tilt" can deliver better than +/- 2% uniformity on substrates which can be up to triple the diameter of the source targets.



PHASE II-J COMPUTER CONTROL



AJA International's Labview based Phase II-J computer control system is used on all ATC systems including the ATC ORION versions. This straightforward, user friendly control system utilizes a large, flat-screen laptop in a 19" rack drawer connected to a single 7" high x 19" wide rack mount hardware module. The back panel of the hardware module is populated with connectors to interface to all aspects of the sputtering system.

The Phase II-J control system allows the user to operate in either the "manual mode" or the "automated processing mode". In the "automated processing mode" the user designs process "layers" which are then compiled and saved as a "process." The system allows 10 unique user entry points which are accessible only by password, limiting access to a user's layers and preventing unexpected corruption of a user's saved processes.



The standard Phase II-J control system will accommodate up to (5) DC power supplies, (4) RF power supplies, (1) 4-way DC switchbox, (1) 3-way RF switchbox, (4) process gases, closed loop automatic pressure control and substrate temperature control. Processes are aborted if plasma is not detected. Special "soak layers" can be easily incorporated into the process. Finally, data logging is standard with an adjustable refresh period. Process data can be downloaded to common spreadsheet programs.

SUBSTRATE HOLDERS / HEATERS

AJA International Inc.'s ATC Series Thin Film Deposition Systems are available with either motorized, rotating substrate holders (for con-focal configurations) or "T" arm substrate holders (for direct deposition). AJA's experienced design and manufacturing team also offers custom substrate holders to satisfy unique requirements.

SHQ Series substrate heaters can achieve temperatures of up to 850° C (special heaters to 1000° C are available for small substrates) and feature reactive gas injection rings, substrate RF and DC bias capability for pre-cleaning and ion assisted deposition, in-situ manual or motorized Z motion for working distance adjustment and load-lock transfer, transverse magnetic field with in-situ orientation adjustment between layers and in-situ mask exchange (available only with certain configurations).

AJA International, Inc. manufactures its own PID temperature controllers and joystick actuated motor controllers for rotation and Z motion. AJA SHQ Series substrate heaters utilize cost effective, durable, fast cycling quartz halogen lamp technology. Custom cooled substrate carriers (air / water / LN 2 / LHe) are also available depending on the requirement.

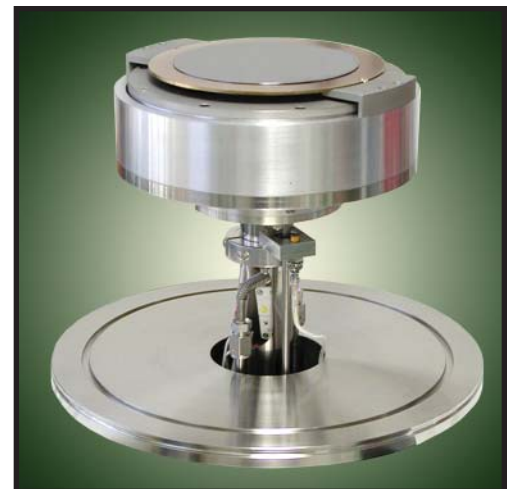
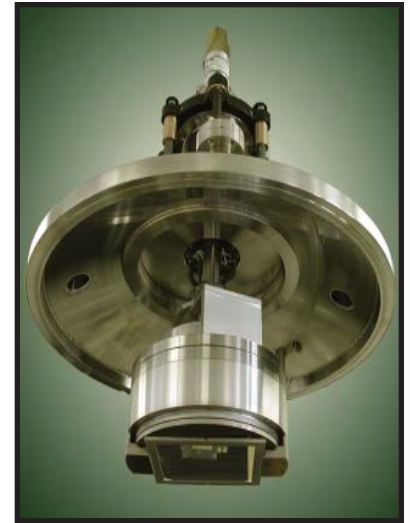
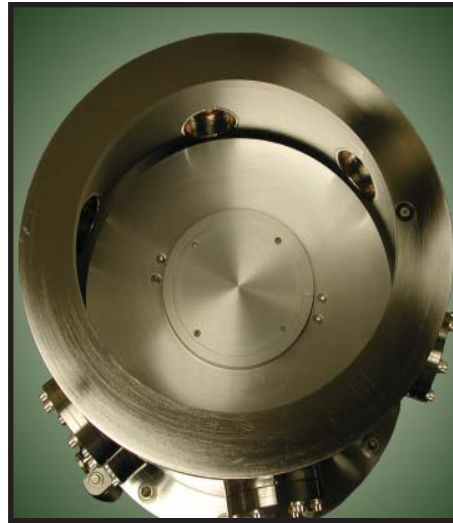

TYPICAL ATC SERIES SYSEM SCHEMATICS

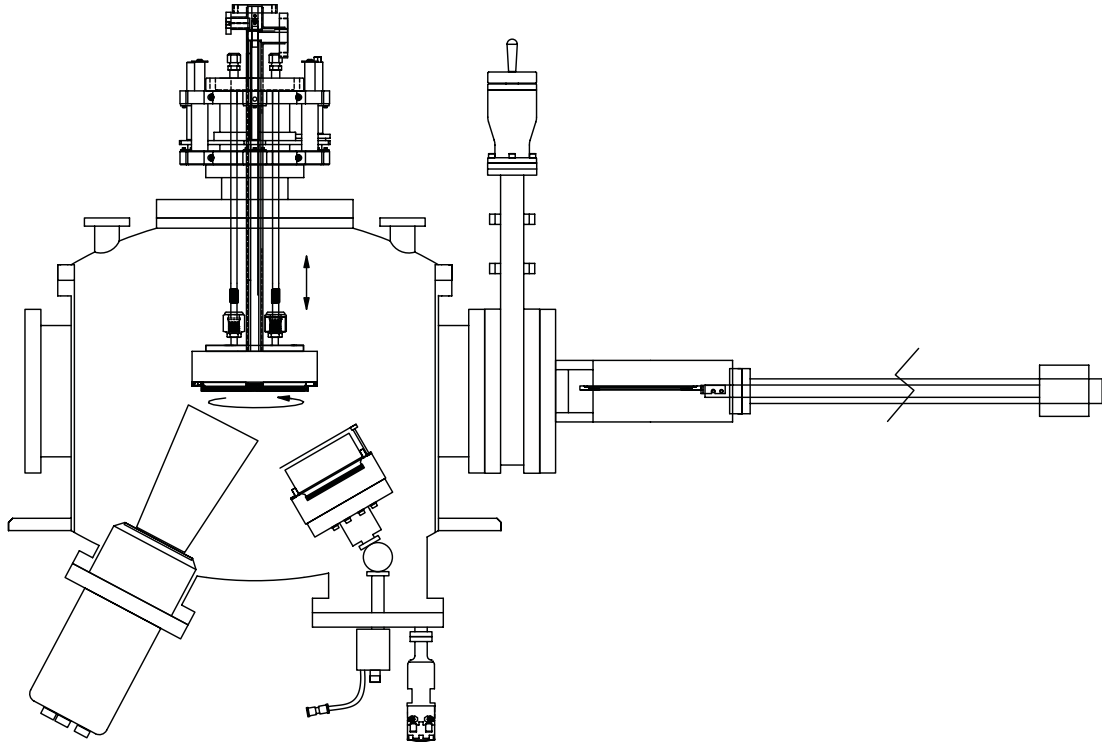

ATC 2200 IBAD with (3) A340-XP 4" UHV sputter sources with in-situ tilt, a COPRA ICP plasma/ion source for ion beam assisted deposition below 5×10^{-4} Torr, 800° C rotating substrate heater with RF bias and motorized Z motion and a load-lock for 6" diameter substrates.

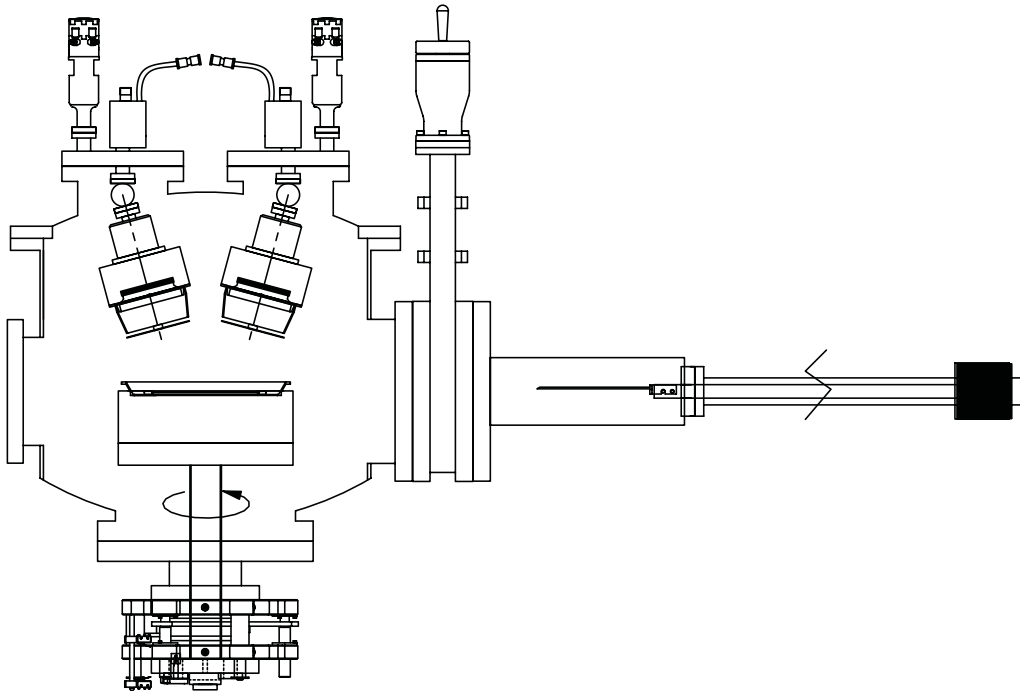

ATC 1800 Sputter Down with (3) ST-30 3" HV sputter sources with in-situ tilt, 800° C rotating substrate heater with RF bias, and a load-lock for 8" diameter transferable substrate trays.

TYPICAL ATC SERIES SYSEM SCHEMATICS

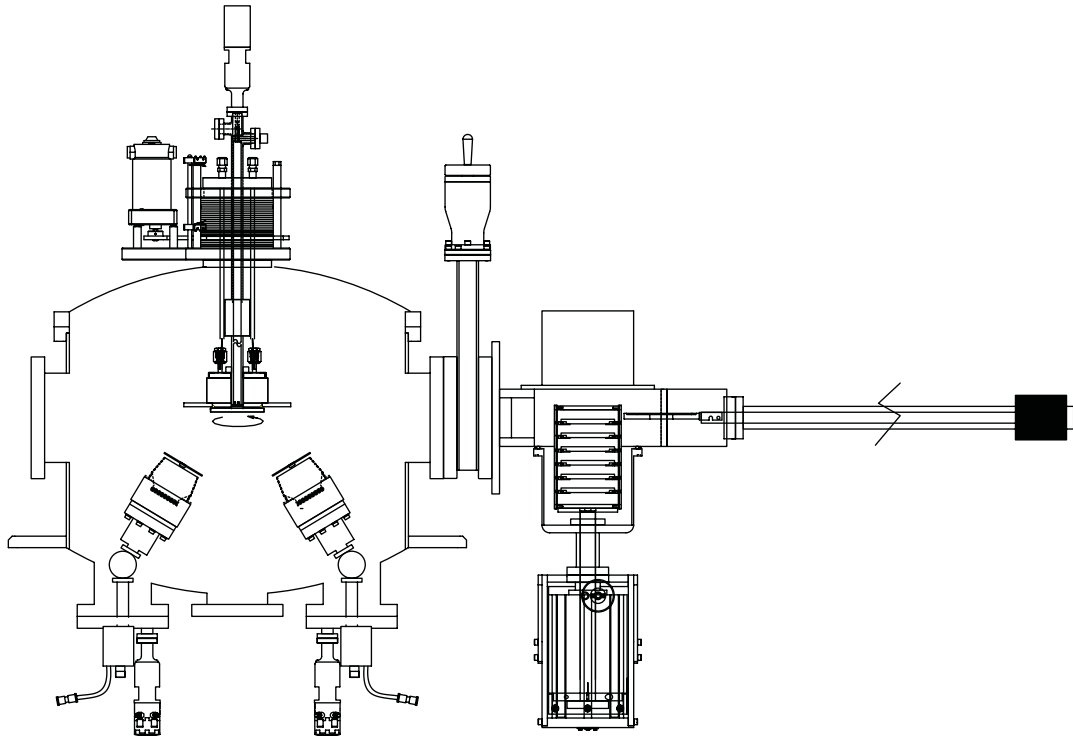

ATC 2400 with (6) A320-XP 2" UHV sputter sources with in-situ tilt, 850° C rotating substrate heater with RF bias and motorized Z motion and cassette load-lock for (6) transferable 4" substrate carriers.

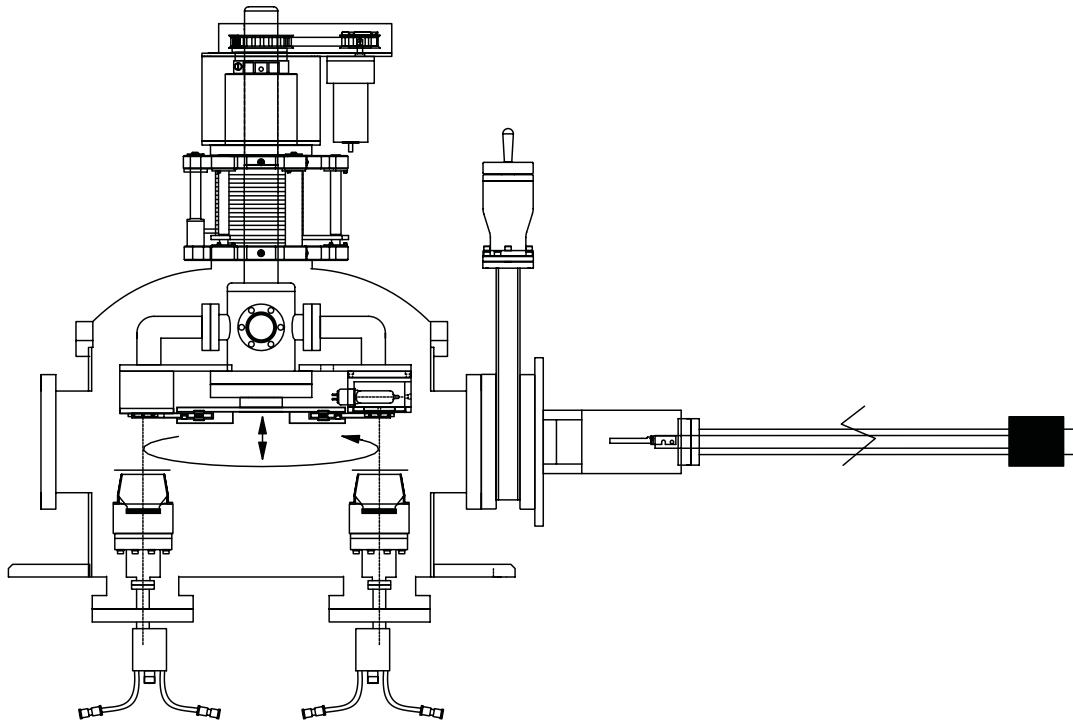

ATC 2000 with (6) A320-XP 2" UHV sputter sources, Heating/Cooling inverted "T" arm, indexing substrate holder for 1.5" diameter samples (1000° C and LN2) with RF bias, and load-lock for 4" substrates.

SYSTEM OPTIONS



MAGNETRON SPUTTER SOURCES WITH IN-SITU TILT



SUBSTRATE HOLDERS WITH HEATING / COOLING / ROTATION

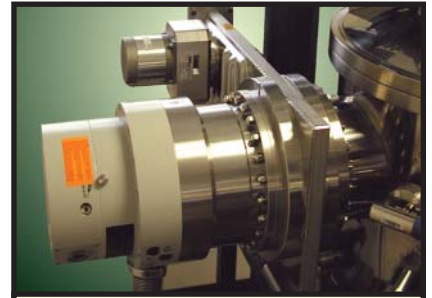

WIDE RANGE TURBOMOLECULAR & CRYOGENIC VACUUM PUMPS

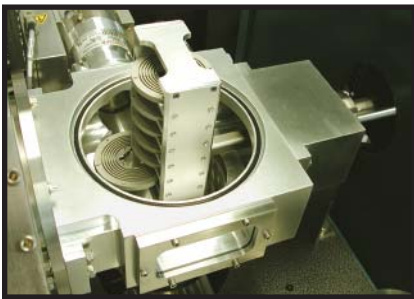

TURBO-PUMPED CASSETTE LOAD LOCK FOR 3", 4", 5" & 8" SUBSTRATES

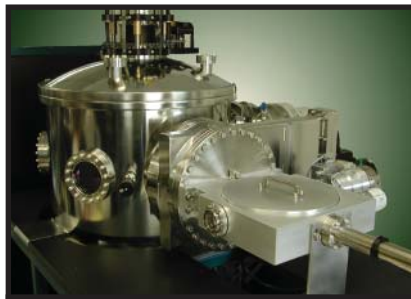

TURBO-PUMPED LOAD LOCK FOR SUBSTRATES UP TO 8" IN DIAMETER

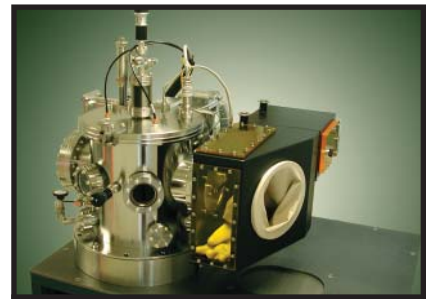

N₂ GLOVE BOX LOAD LOCK FOR SUBSTRATES UP TO 6" IN DIAMETER



POWER DISTRIBUTION MODULES



MFC GAS HANDLING



COMPUTER CONTROL



RF & DC POWER SUPPLIES



SPUTTERING TARGETS



AUTOMATIC PRESSURE CONTROL



RF / DC POWER SUPPLIES

AJAINT.COM/RFDC.HTM

AJA INTERNATIONAL, INC.

GENERAL INFORMATION



International, Inc. offers DC and RF power supplies from 100W to 40kW. DC power supplies feature efficient switching technology, power / current / voltage regulation, arc suppression, remote connector and interlocks. RF power supplies are fully programmable with process storage and power ramping to reduce thermal stress on targets. Manual and automatic matching networks are available. Automatic matching networks include one vacuum and one air capacitor for optimum reliability. Air cooled matching is the standard configuration with water cooled versions available. CE versions of most power supplies can be provided.

AJA 100/300 WATT MANUAL MATCH RF GENERATORS



The AJA International A100RF/A100MM and A300RF/A300MM are manually matched 100 and 300 Watt, 13.56 MHz generators with an integrated 3 way output switch on the matchbox allowing connection to up to 3 loads. These lightweight, air-cooled units are designed to exceed the most stringent vacuum processing demands. They can be used to operate small magnetron sputter sources or for RF plasma biasing of substrate carriers for pre-clean etching or ion assisted deposition. The front panel controls and indicators are logically grouped, with operational status shown on the front panel four line fluorescent display. AJA RF generators incorporate a single surface mount technology printed circuit board for controls and for the RF amplifier. The RF amplifier is powered by a switch-mode power supply.

AJA RF generators utilize Field-Effect Transistors in the exciter and power amplifier stages. The unit operates in a class AB mode providing power accuracy and stability across the entire power range.

AJA 300/600 WATT AUTO MATCH RF GENERATORS



The AJA International A300RF/A300MU and A600RF/A600MU are 300 Watt and 600 Watt RF packages, including a 13.56 MHz generator and automatic matching network. These lightweight, half-rack units are designed to exceed the most stringent vacuum processing demands. They can be used to operate small magnetron sputter sources or for RF plasma biasing of substrate carriers for pre-clean etching or ion assisted deposition. The front panel controls and indicators are logically grouped, with operational status shown on the front panel four line fluorescent display.

AJA RF generators incorporate a single surface mount technology printed circuit board for controls and for the RF amplifier. The RF amplifier is powered by a switching power supply.

AJA RF generators utilize Field-Effect Transistors in the exciter and power amplifier stages. The unit operates in a class AB mode providing power accuracy and stability across the entire power range. For maximum reliability in a wide variety of applications, these RF generators are rated at 50% of their actual design capability, and are protected against excessive Voltage Standing Wave Ratio (VSWR) conditions by limiting reflected power, power amplifier current, and power amplifier transistor dissipation.

The A300RF/A300MU and A600RF/A600MU carry CE Marking (EMC and Safety) and meet FCC regulations for spurious radiated emissions.

AJA DCXS POWER SUPPLY



AJA International, Inc. now offers a new generation of switching DC power supplies specifically designed for the R&D magnetron sputtering market. These new units are available in 750 Watt and 1500 Watt sizes and feature integral 3 way or 5 way switch-boxes. Each generator has either 3 or 5 coaxial outputs which are connected to separate magnetron sources. The desired source is selected from either the front panel or via the I/O. The supply also includes 24 V shutter actuation, programmable ramping, deposition timer and shutter delay. These features allow the user to program a complete deposition from strike, to ramp up, to pre-sputter for a selected time, to shutter open for a selected time, to shutter close, to ramp down, to plasma off. This programmed sequence is subsequently initiated with a single command. Finally the supply permits the end user to specify the target material in each source and monitors the consumption of these materials. When the target has been consumed to a user specified point, the supply alerts the user from the front panel by a flashing signal.

ADVANCED ENERGY / PINNACLE PLUS / SPARKLE

AJA International, Inc offers a wide variety of power supplies that are compatible with our production sputtering sources. AJA International Inc. can help you determine what type of power supply best suits your needs based on the type of source you choose, your target size and application. Available options include:

- DC / PULSED DC
- RF
- HIPIMS
- AC

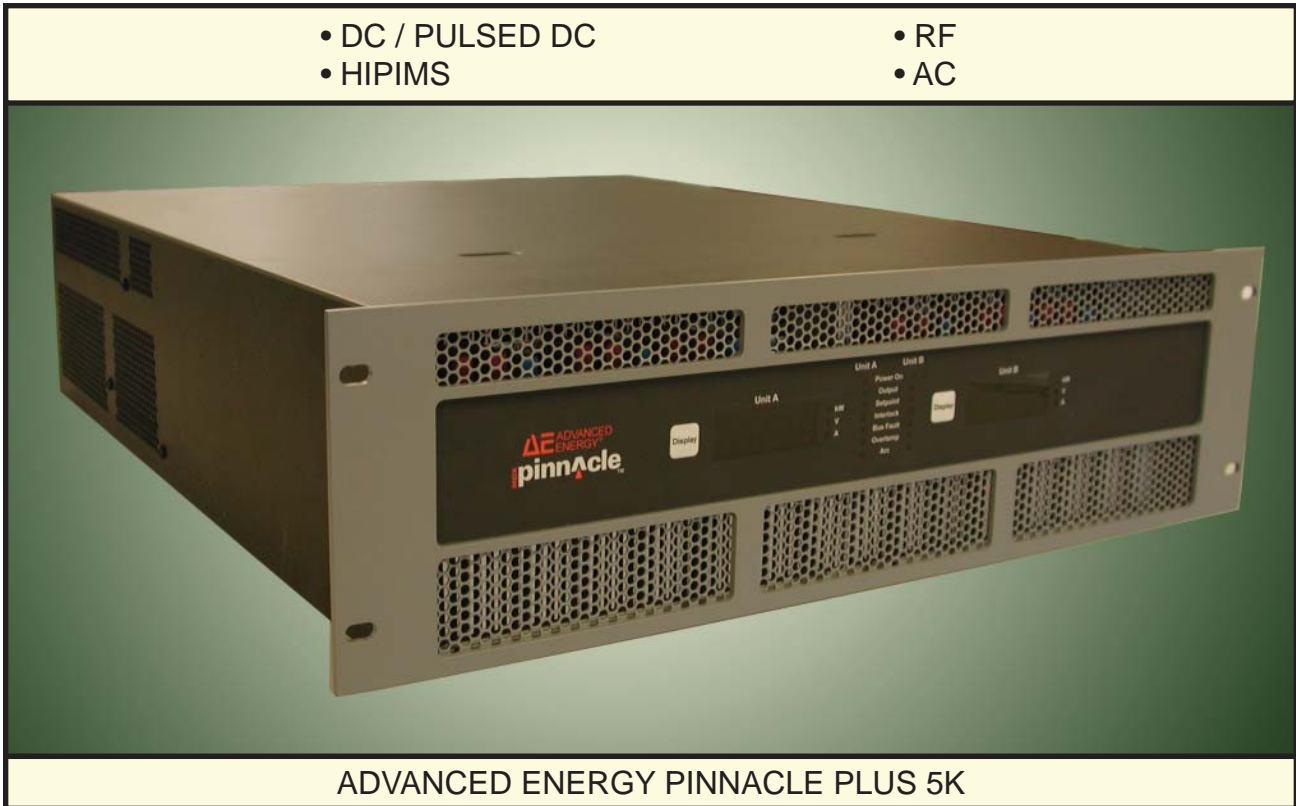

ADVANCED ENERGY PINNACLE PLUS 5K

CHEMFILT HP PULSE DC POWER SUPPLY

Chemfilt IonSputtering is introducing Sinex 2.0-AS14, the latest High Impact Power Impulse Magnetron Sputtering (HIPIMS) power supply. Sinex 2.0-AS14 is a versatile power supply dedicated for use with HIPIMS processes and offers next generation process control with highly ionized sputtered materials.



KEY FEATURES

- 1.4 MW pulsed power
- Simple Operation
- Variable pulse setting
- Arc Suppression
- Firmware upgradeable via PC USB
- Voltage / current monitor outputs
- Standard 19" rack montage



SUBSTRATE HOLDERS

AJA INTERNATIONAL, INC.

GENERAL INFORMATION

Since 1989 AJA International, Inc. has developed and manufactured a wide variety of UHV and High Vacuum substrate heaters and rapid annealing stations based on quartz lamp technology. All designs are 100% oxygen compatible and engineered with high power lamp elements that are economical, easily serviced and will operate for extended periods of time.

AJA's reliable SHQ-X Series substrate heaters deliver up to 5000 Watts of radiant heat to either fixed or rotating substrate holders and reaching temperatures of up to 1000°C. Models are available for 1" - 12" diameter substrates and squares up to 200 mm x 200 mm. Optional transferable substrate carriers are available which will allow the heaters to accommodate either full size substrates or a number of small samples.

RF (or DC) biasing is optional for fixed and rotating models and permits both substrate pre-cleaning and simultaneous, low energy ion bombardment during deposition to enhance adhesion, film density and film properties. Reactive gas injection rings / distributors and manual / motorized positioning are also available on most units.

For applications requiring a combination of heating and cooling in the same process, AJA International, Inc. offers the unique SHQ-V (0°C to 600°C) and SHQ-C (70°K to 600°C) designs. In applications where cooling only is required, AJA has built numerous substrate coolers with the ability to keep substrates between 70°K and 80°C using either LHe, LN2, water or cool air. Custom engineering is available if a proven design is not already at hand.

Finally, to provide a fully integrated, cost effective solution, AJA builds its own compact SHQ-15A/25A PID power supply / temperature controller units and MXMC (multi axis) and SXMC (single axis) motor controllers.

SHQ-F - FIXED SUBSTRATE HEATERS / RAPID ANNEAL / OXYGEN FURNACE

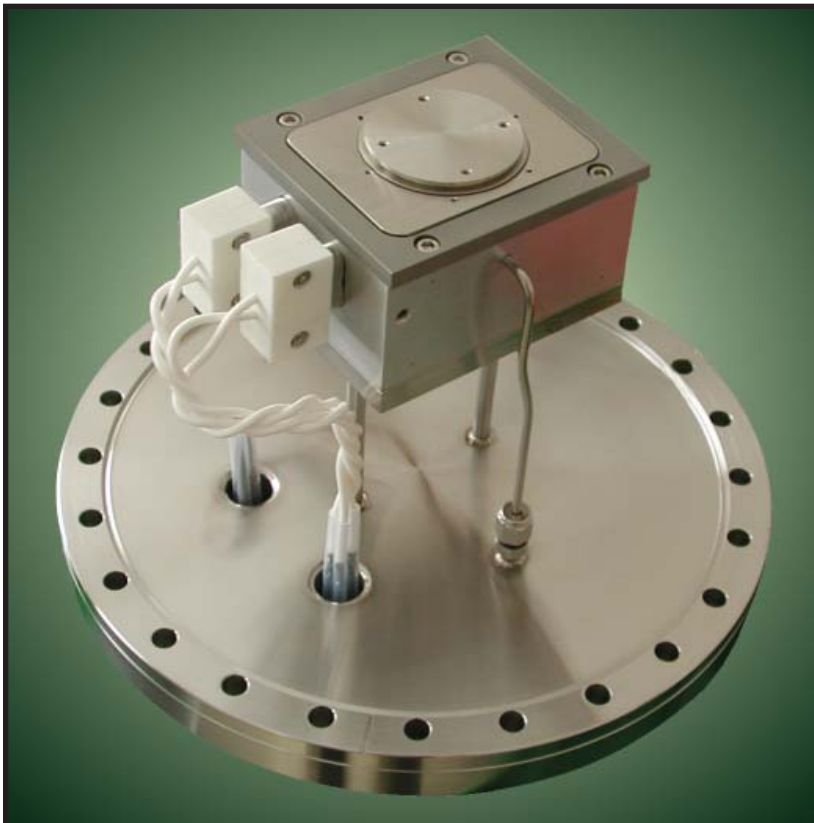

For applications where the substrate is fixed in front of one or two quartz lamps, AJA builds 1" and 2" diameter HV and UHV heaters which reach 1000°C. For 3" to 8" fixed substrates, substrate heaters, annealing stations and oxygen furnaces are available which can achieve 500°C to 900°C depending on requirements and design constraints.

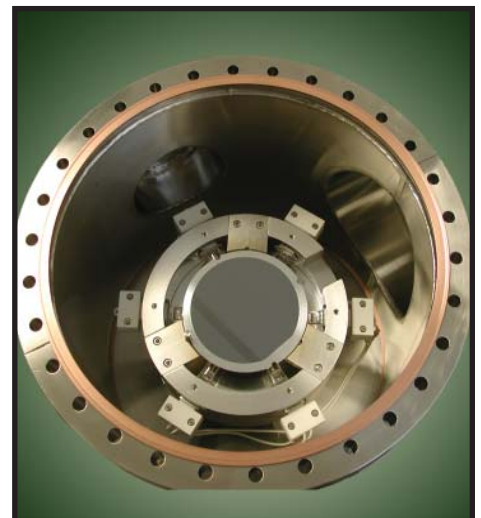

SHQ-X - ROTATING SUBSTRATE HEATERS



Substrate rotation in front of AJA's unique quartz lamp array optimizes both temperature and thin film deposition uniformity. SHQ-3X (up to 3" dia. substrates) and SHQ-4X (up to 4" diameter substrates) will achieve temperatures up to 850°C. SHQ-6X, SHQ-8X, SHQ-10X and SHQ-12X accommodate substrates from 6" to 12" diameter and can reach temperatures of up to 800°C. RF / DC biasing is optional.

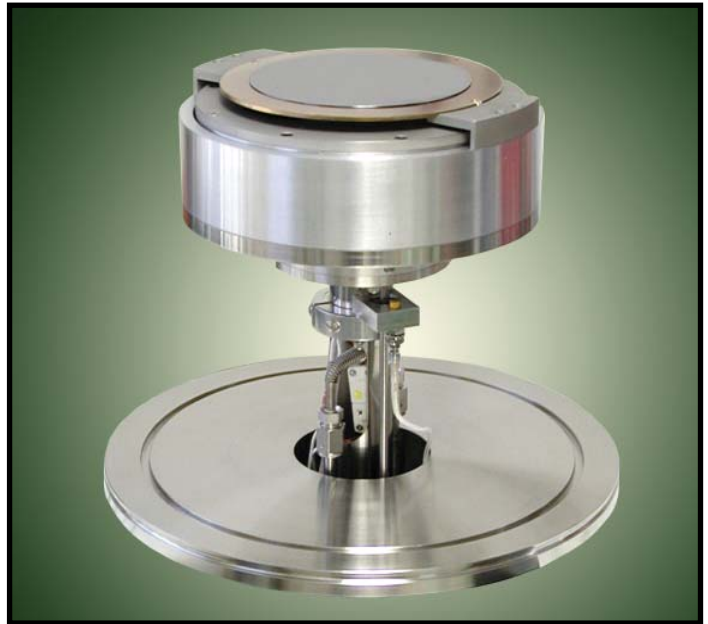

SHQ-V/C - COMBINATION HEATING COOLING



In applications where substrate heating and cooling is required in the same process, AJA has developed the unique SHQ-V (0°C to 600°C) and SHQ-C (70°C to 600°C). These units are designed for 4", 6" and 8" substrates and utilize quartz lamps and either LHe, LN₂, or cool air. This "dry" cooling thus eliminates the need to drain the system when in the heating mode. A ferrofluid seal and motorized rotation system facilitate both uniform deposition, uniform heating and a well protected cooling delivery system. Motorized "Z" motion and RF / DC bias are available options on certain models.

SHQ-C - COOLED SUBSTRATE HOLDERS

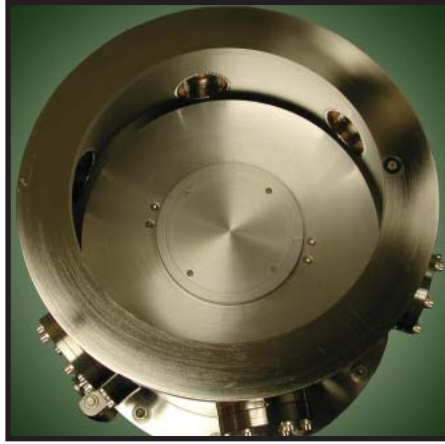

AJA International, Inc. also manufactures a variety of substrate cooling stages. Optional features include rotation, RF/DC biasing, motorized Z motion, LHe, LN₂, water cooling or air cooling. Substrate sizes from 1" - 12" diameter can be accommodated depending on the specific design. Custom engineered solutions are often required to meet the specific application.

SHQ-CES - CUSTOM ENGINEERED SOLUTIONS



AJA International, Inc. has custom engineered dozens of special substrate heater solutions since 1989. Versions include heaters for square substrates, heaters with a transverse magnetic field, in-situ motorized tilt (shadow depositions) and mask exchange systems (combinatorial chemistry and general patterning). If a custom design is required, please provide details and a sketch if possible and e-mail or fax your requirement to AJA for a prompt quotation.

SHQ-15A/25A - PID POWER SUPPLY / TEMPERATURE CONTROLLER



AJA International, Inc. manufactures two PID temperature controller / power supply units, the SHQ-15A (up to 2500 Watts) and the SHQ-25A (up to 5000 Watts). Both require 190 V - 240 V single phase power input and deliver +/- 1°C temperature stability and feature auto-tuning, over-temp alarm, external interlock and local/remote selector switch. Both models are half rack width x 3U.

SHQ-SXMC/MXMC - SINGLE AND MULTI AXIS MOTION CONTROLLER



The SXMC (single axis motor controller) is used in "rotation only" designs. The MXMC (multi axis motor controller) is used to rotate the substrate and to control a motorized bellows for Z motion. Z motion is useful for adjusting working distances in deposition systems and in transfer and/or analysis. The SXMC has a single SPEED potentiometer with LED. The MXMC adds a 4 position joystick (Up / Down / Jog CW / Jog CCW) which controls both the rotation and the Z motion motors. The MXMC features a momentary limit bypass on the front panel and both units can be ordered with a remote control interface. These controllers require a 190 V - 240 V single phase power input and are designed to drive 12 VDC gearmotors.

www.ajaint.com

AJA INTERNATIONAL, INC.

topgun@ajaint.com

809 COUNTRY WAY * NORTH SCITUATE, MA 02066 * USA * T: 781-545-7365 * F: 781-545-4105



MICROWAVE POWER SUPPLIES

AJAINT.COM/MICROWAVE.HTM

AJA INTERNATIONAL, INC.

GENERAL INFORMATION

Since it was founded in 1978, Sairem has manufactured hundreds of generators (100 W to 75 KW) for a wide variety of industrial and semiconductor applications. AJA International, the U.S sales, marketing and service organization for these products, specializes in thin film and materials processing technologies. This collaboration provides our customers with an extensive experience base, ranging from ECR processing to industrial plasma applications. Please visit www.sairem.com for more information.

KEY FEATURES

- EXCELLENT POWER AND FREQUENCY STABILITY
- LOW RIPPLE
- COMPACT, LIGHTWEIGHT SWITCHING TECHNOLOGY
- SHORT RESPONSE TIME
- USER FRIENDLY CONTROLS
- PROTECTION CIRCUITRY
- REMOTE CONTROL

APPLICATIONS

- ECR DEPOSITION AND ETCHING
- DOWNSTREAM MICROWAVE PROCESSING
- ION SOURCES
- DIAMOND FILM DEPOSITION
- MICROWAVE HEATING AND SINTERING

